

General · Allgemein · Généralités
 Generalidades · Generalità · Общие положения

Vehicle dimensions · Fahrzeugabmessungen · Dimensions du véhicule
 Dimensiones del vehículo · Dimensioni veicolo · Габариты машины

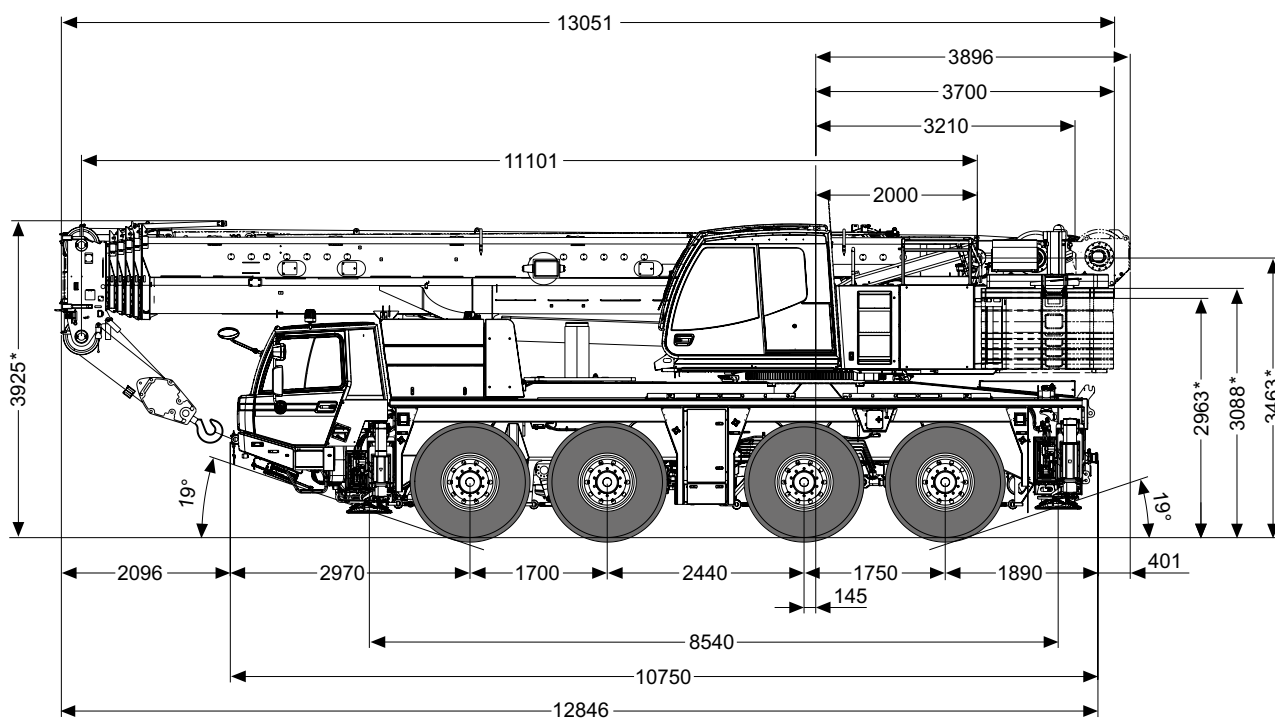

* ± 100

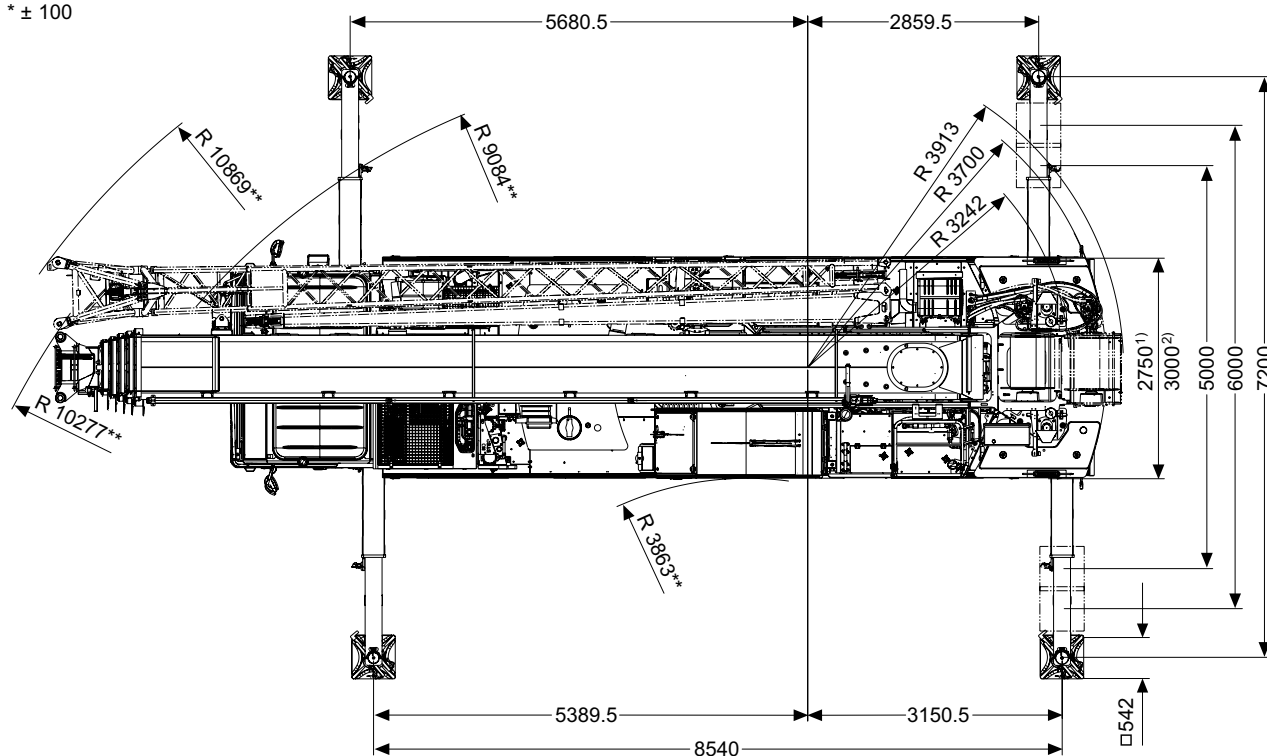

** Minimum · minimum · mínimo · minimo · мінімальні

¹⁾ 385/95 R 25 (14.00 R25), 445/95 R 25 (16.00 R25)

²⁾ 525/80 R 25 (20.5 R25)

Operation · Einsatz · Utilisation
 Uso · Эксплуатация

Working range · Arbeitsbereich · Rayon de travail
 Zona de trabajo · Area di lavoro · Рабочая зона

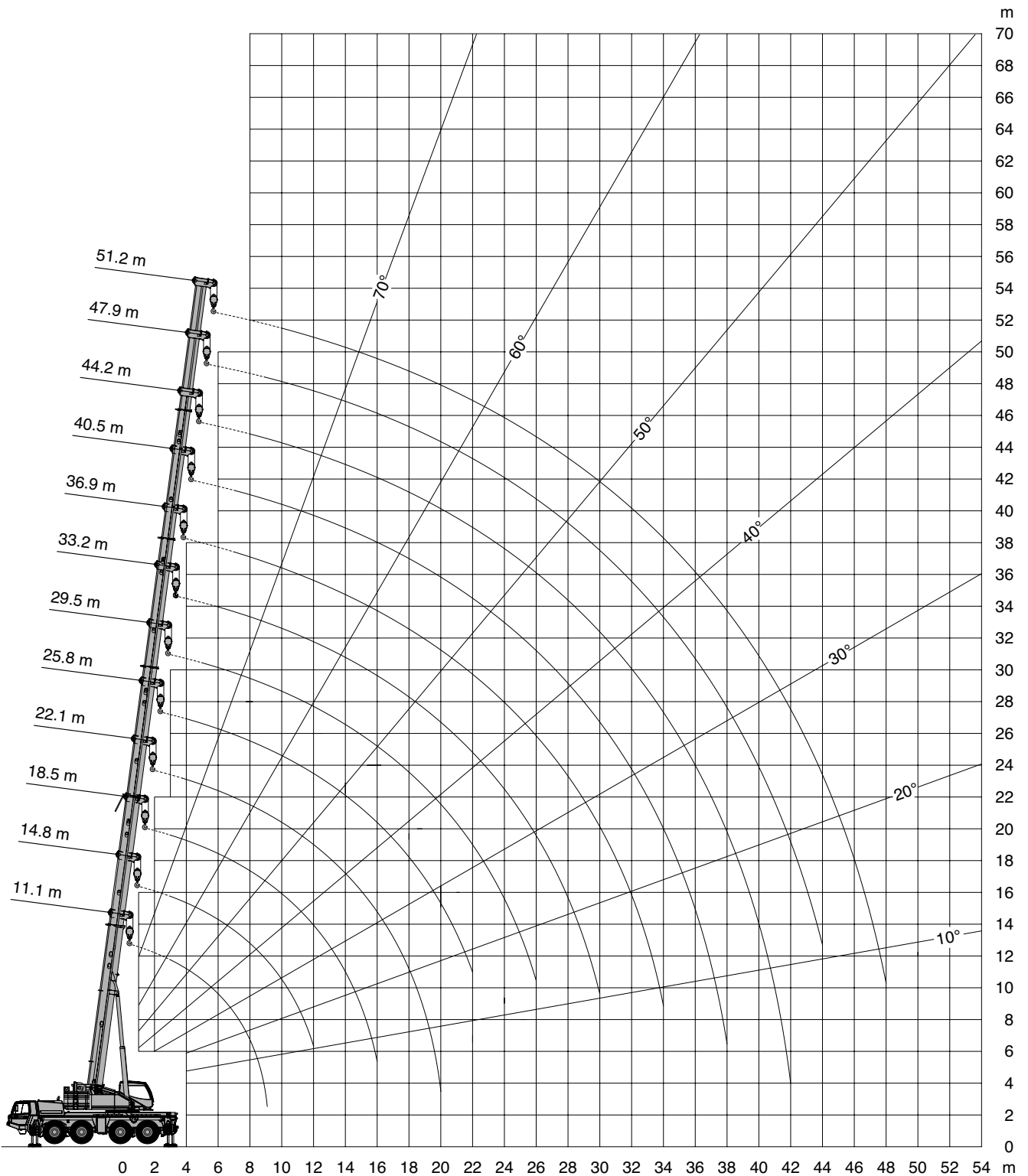

Lifting capacities · Traglasten · Charges de levage
Cargas · Portate · Грузоподъемность

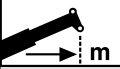

 m	11.1 m*	11.1 m	14.8 m	18.5 m	22.1 m	25.8 m	29.5 m	33.2 m	36.9 m	40.5 m	44.2 m	47.9 m	51.2 m
2.3	100.0**												
2.5	90.0**												
3.0	81.6**	76.1**	65.0	65.0									
3.5	74.6	69.9	65.0	65.0	50.0								
4.0	68.3	64.1	63.5	61.4	50.0	41.3							
4.5	62.7	59.0	58.5	56.7	50.0	41.3							
5.0	57.8	54.6	54.0	52.7	50.0	39.2	31.6						
6.0	50.0	47.2	46.6	46.8	45.9	34.9	31.6	23.8					
7.0	42.5	41.2	40.7	40.8	40.8	33.0	28.9	23.8	19.7	15.8			
8.0	36.6	35.5	35.4	35.5	35.8	31.1	28.5	23.8	19.7	15.8	12.9		
9.0	24.9	24.0	31.2	31.4	31.6	29.4	28.5	22.6	19.7	15.8	12.9	10.2	
10.0			26.7	26.9	27.3	28.0	27.0	20.9	19.6	15.8	12.9	10.2	8.9
11.0			22.7	23.4	24.7	24.9	24.0	19.4	18.2	15.8	12.9	10.2	8.9
12.0			20.0	21.9	21.9	21.7	21.3	18.0	17.0	15.8	12.9	10.2	8.9
14.0				17.2	17.3	17.0	16.6	16.2	14.9	14.1	12.9	10.2	8.9
16.0				14.0	14.1	13.8	13.4	13.9	13.0	12.6	11.8	10.2	8.9
18.0					11.7	11.5	11.1	11.5	11.7	10.8	10.8	10.0	8.9
20.0					9.2	9.7	9.3	9.7	9.9	9.5	9.5	9.1	8.5
22.0						8.3	8.4	8.3	8.5	8.6	8.4	8.1	7.6
24.0							7.8	7.2	7.7	7.4	7.3	7.0	6.9
26.0							6.9	6.5	6.7	6.5	6.3	6.0	6.0
28.0								6.0	5.9	5.7	5.5	5.2	5.2
30.0								5.3	5.2	5.0	4.8	4.5	4.5
32.0									4.7	4.4	4.3	3.9	3.9
34.0									4.2	3.9	3.7	3.4	3.4
36.0										3.5	3.3	3.0	3.0
38.0										3.1	2.9	2.6	2.6
40.0											2.6	2.2	2.2
42.0											2.3	1.9	1.9
44.0												1.7	1.6
46.0													1.4
48.0													1.2



 m	11.1 m*	11.1 m	14.8 m	18.5 m	22.1 m	25.8 m	29.5 m	33.2 m	36.9 m	40.5 m	44.2 m	47.9 m	51.2 m
2.3	100.0**												
2.5	90.0**												
3.0	81.6**	76.6**	65.0	65.0									
3.5	74.5	69.7	65.0	65.0	50.0								
4.0	67.9	63.8	63.3	61.4	50.0	41.3							
4.5	62.3	58.7	58.2	56.7	50.0	41.3							
5.0	57.5	54.2	53.7	52.7	50.0	39.2	31.6						
6.0	49.1	46.8	46.3	46.4	45.9	34.9	31.6	23.8					
7.0	41.5	40.5	40.0	40.1	39.4	33.0	28.9	23.8	19.7	15.8			
8.0	35.8	35.3	34.8	34.1	32.9	31.1	28.5	23.8	19.7	15.8	12.9		
9.0	24.9	24.0	29.1	28.9	28.1	28.7	27.0	22.6	19.7	15.8	12.9	10.2	
10.0			24.1	24.7	26.3	25.1	23.7	20.9	19.6	15.8	12.9	10.2	8.9
11.0			20.9	22.9	22.9	22.2	21.0	19.4	18.2	15.8	12.9	10.2	8.9
12.0			19.4	19.9	20.0	19.7	18.7	17.8	17.0	15.8	12.9	10.2	8.9
14.0				15.6	15.7	15.4	15.0	15.3	14.0	13.7	12.9	10.2	8.9
16.0				12.7	12.7	12.5	12.1	12.5	12.8	11.4	11.4	10.2	8.9
18.0					11.0	10.3	10.1	10.4	10.6	10.3	10.3	9.8	8.9
20.0					9.4	8.9	9.2	8.7	9.1	9.0	8.9	8.4	8.2
22.0						8.0	8.1	7.7	7.9	7.7	7.5	7.2	7.2
24.0							7.1	6.9	6.9	6.6	6.5	6.1	6.1
26.0							6.2	6.0	6.0	5.7	5.6	5.3	5.3
28.0								5.3	5.2	5.0	4.8	4.5	4.5
30.0								4.7	4.6	4.4	4.2	3.9	3.9
32.0									4.1	3.8	3.7	3.4	3.4
34.0									3.6	3.4	3.2	2.9	2.9
36.0										2.9	2.8	2.5	2.5
38.0										2.6	2.4	2.1	2.1
40.0											2.1	1.8	1.8
42.0											1.8	1.5	1.5
44.0												1.2	1.2
46.0													1.0
48.0													0.8

* Over rear · Nach hinten · A l'arrière · Hacia atrás · Indietro · Назад

** With additional lifting equipment · Mit Zusatzhubausrüstung · Avec équipement de levage supplémentaire

Con equipamiento de elevación adicional · Con attrezzaggio di sollevamento supplementare · С дополнительным подъемным оборудованием